



Chapter5: Exercises

Silvia Giordano

ICA, EPFL

Exercise1

- Derive the maximum efficiency of ALOHA and slotted ALOHA.

Aloha & Slotted Aloha efficiency

Suppose N stations have packets to send

- each transmits in slot with probability p
- prob. successful transmission S is:

by single node: $S = p (1-p)^{(N-1)}$

by any of N nodes

$$S = \text{Prob (only one transmits)} = N p (1-p)^{(N-1)}$$

ALOHA

The value of p (p^*) that maximises the efficiency of ALOHA is:

$$E(p) = Np(1 - p)^{2(N-1)}$$

$$E'(p) = N(1 - p)^{2N-2} - Np2(N-1)(1 - p)^{2(N-3)}$$
$$= N(1-p)^{2(N-3)} ((1 - p) - p2(N-1))$$

$$E'(p) = 0 \Rightarrow p^* = 1/(2N-1)$$

Using this value, the max efficiency of ALOHA is;

$$\lim_{(N \rightarrow \text{infinity})} E(p^*) = \frac{1}{2} * \frac{1}{e} = \frac{1}{2e}$$

Slotted ALOHA

The value of p (p^*) that maximises the efficiency of slotted ALOHA is:

$$E(p) = Np(1 - p)^{N-1}$$

$$E'(p) = N(1 - p)^{N-1} - Np(N-1)(1 - p)^{N-2}$$

$$= N(1-p)^{N-2}((1 - p) - p(N-1))$$

$$E'(p) = 0 \Rightarrow p^* = 1/N$$

Using this value, the max efficiency of slotted ALOHA is;

$$E(p^*) = N \cdot 1/N (1 - 1/N)^{N-1} = (1 - 1/N)^{N-1} = (1 - 1/N)^N / (1 - 1/N)$$

$$\lim_{(N \rightarrow \text{infinity})} (1 - 1/N) = 1 \quad \lim_{(N \rightarrow \text{infinity})} (1 - 1/N)^N = 1/e$$

$$\text{Thus: } \lim_{(N \rightarrow \text{infinity})} E(p^*) = 1/e$$

Aloha & Slotted Aloha efficiency

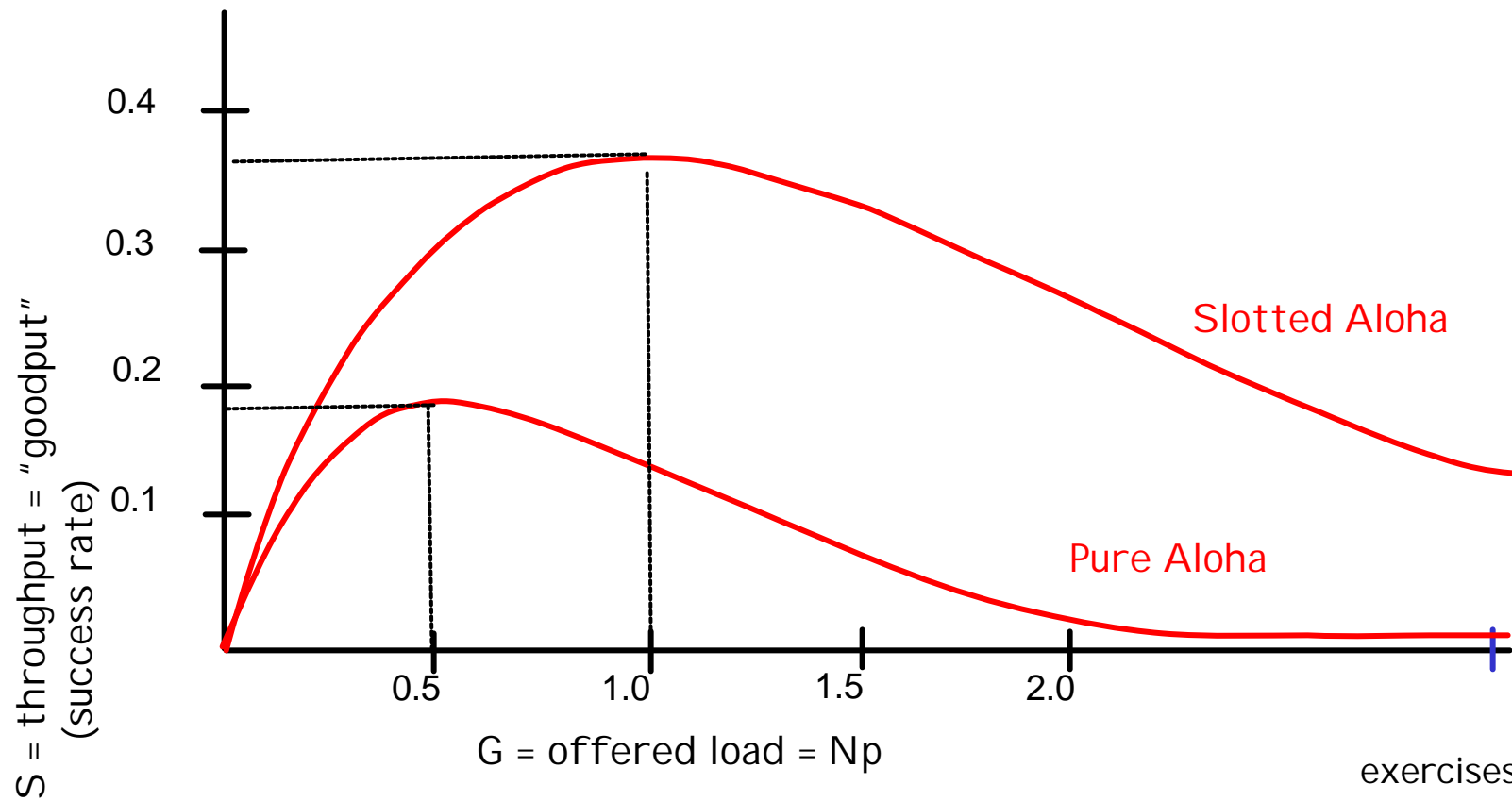

Exercise 2

- Suppose nodes A and B are on the same 10 Mbps Ethernet segment, and the propagation delay between the two nodes is 225 bit times. Suppose node A begins transmitting a frame, and before it finishes, node B begins transmitting a frame. Can A finish transmitting before it detects that B has transmitted?

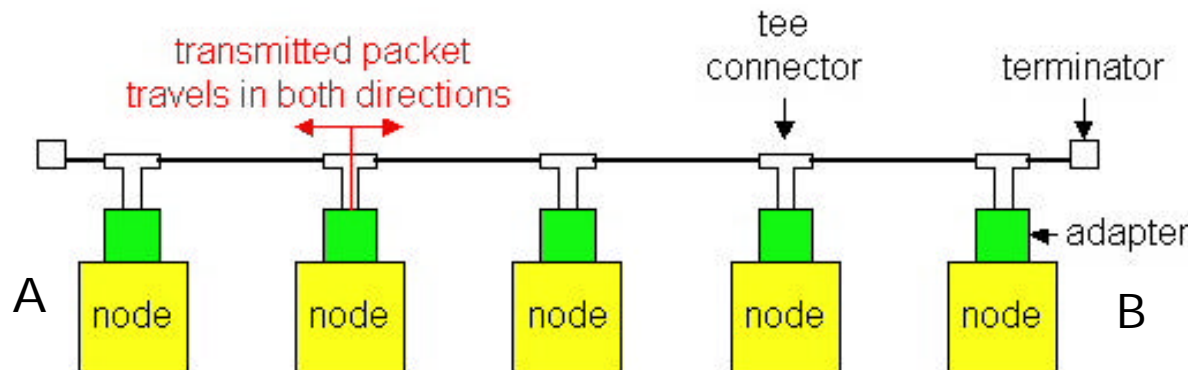

Exercise 2

- Suppose at time $t = 0$ bit times, A begins transmitting a frame.
- In the worst case, A transmit a minimum size frame of $512 + 64$ bit times.
- So A would finish transmitting at $t = 576$.
- In the worst case, B begins transmitting at time $t = 224$.
- At time $t = 224 + 225 = 449$ B's first bit arrives at A.

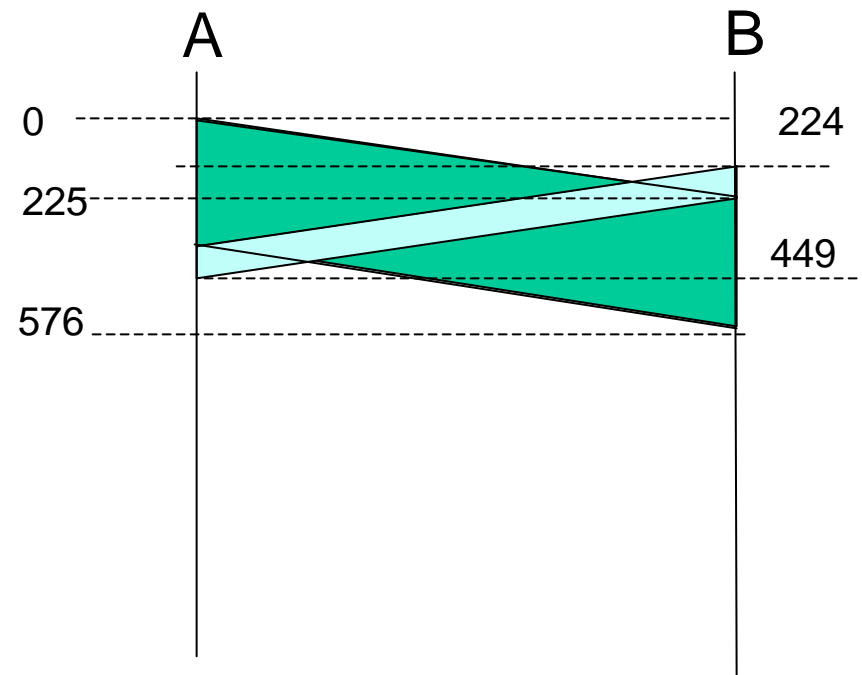

Exercise 2

- Because $449 < 576$, A aborts before completing the transmission of the packet, as it is supposed to do.
- Thus A cannot finish transmitting before it detects that B transmitted.
- This implies that if A does not detect the presence of a host, then no other host begins transmitting while A is transmitting.

Exercise 3

- ❑ Consider three LANs interconnected by two routers, as shown in the diagram below:
 - a. Redraw the diagram to include adapters.
 - b. Assign IP addresses to all of the interfaces. For LAN 1 use addresses 111.111.111.xxx; and for LAN 2 uses addresses of the form 122.222.222.xxx; and for LAN 2 uses addresses of the form 133.133.133.xxx.
 - c. Assign LAN addresses to all of the adapters.
 - d. Consider sending an IP datagram from host A to host F. Suppose all of the ARP tables are up-to-date. Enumerate all the steps for ARP resolution.

Exercise 3

- ❑ Consider three LANs interconnected by two routers, as shown in the diagram below:
 - a. Redraw the diagram to include adapters.
 - b. Assign IP addresses to all of the interfaces. For LAN 1 use addresses 111.111.111.xxx; and for LAN 2 uses addresses of the form 122.222.222.xxx; and for LAN 2 uses addresses of the form 133.133.133.xxx.
 - c. Assign LAN addresses to all of the adapters.
 - d. Consider sending an IP datagram from host A to host F. Suppose all of the ARP tables are up-to-date. Enumerate all the steps for ARP resolution.

Exercise 3: IP and LAN addresses

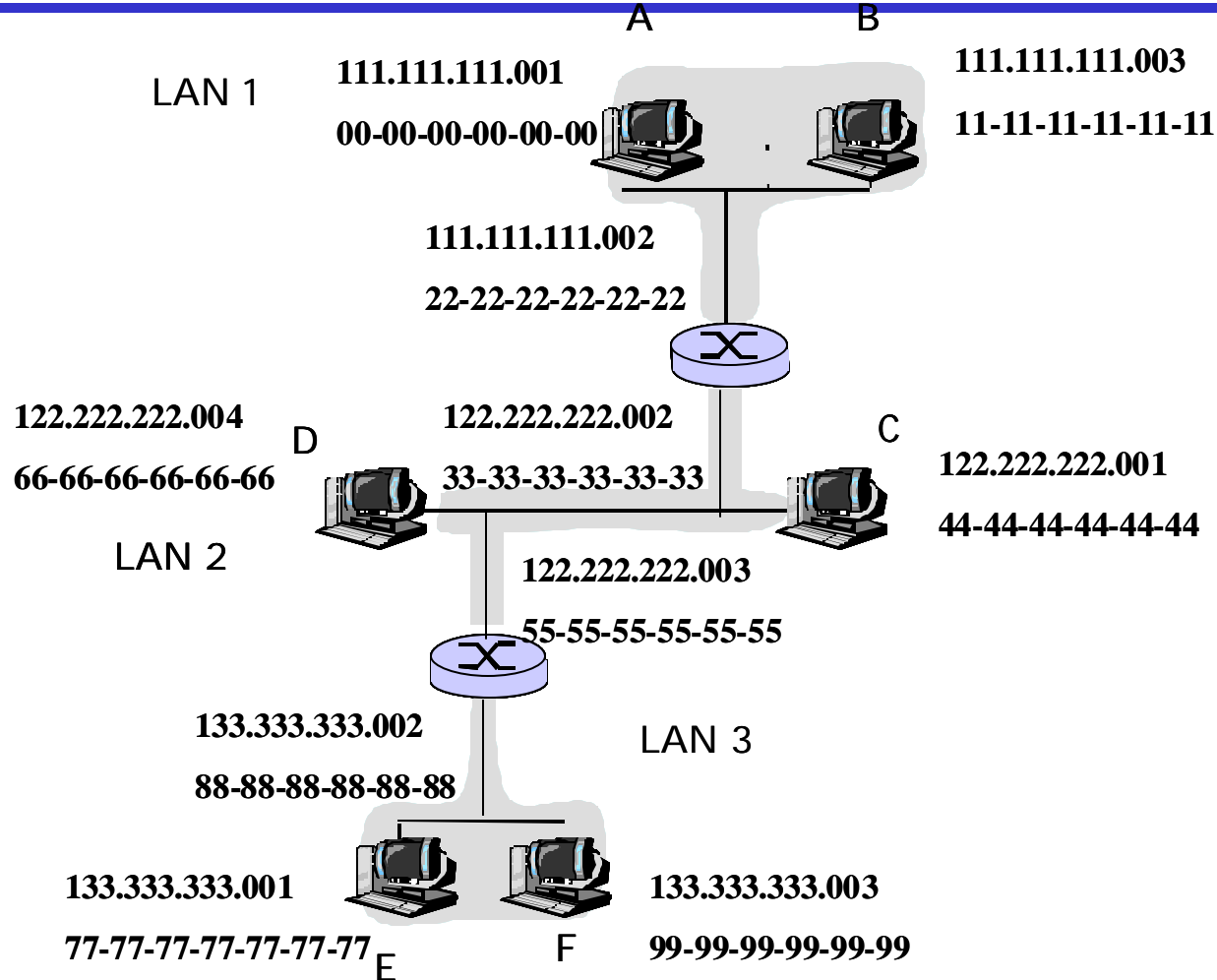

Exercise 3

Consider sending an IP datagram from host A to host F. Suppose all of the ARP tables are up-to-date. Enumerate all the steps for ARP resolution:

1. Routing table in A determines that the datagram should be routed to interface 111.111.111.002.
2. Host A uses ARP to determine the LAN address for 111.111.111.002, namely 22-22-22-22-22.
3. The adapter in A creates an Ethernet packet with Ethernet destination address 22-22-22-22-22-22.
4. The first router receives the packet and extracts the datagram. The routing table in this router indicates that the datagram is to be routed to 122.222.222.003.
5. The first router then uses ARP to obtain the associated Ethernet address, namely 55-55-55-55-55-55.
6. The process continues until the packet has reached Host F.